

# PARTS LIST & SCHEMATIC

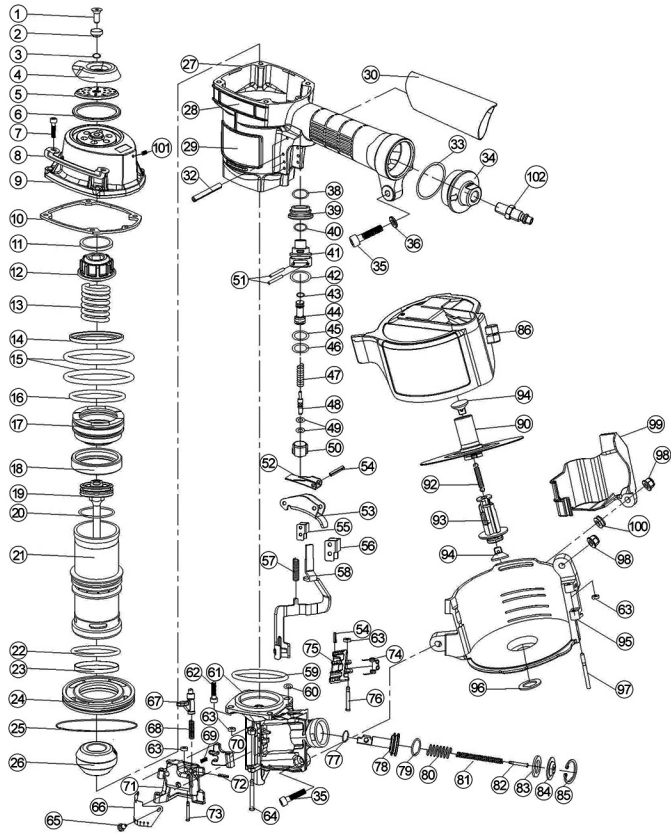

No.	Description	No.	Qty.	Description	Qty.	No.	Description	Qty.	No.	Description	Qty.
01	Hex Bolt M8*20	1	25	O-Ring 74.4*3.1	1	51	Pin 2*15	1	75	Send Nail Claw	1
02	Cylinder Pin	1	26	Bumper	1	52	Hook Stop Lever	2	76	Send Nail Claw Pin	1
03	O-Ring 10*2	1	27	Gun Body	1	53	Trigger	1	77	O-Ring 9.9*2.4	1
04	Exhaust Deflector	1	28	Model Label	1	54	Pin 3*15	1	78	Send Nail Piston	1
05	Exhaust Seal	1	29	Warning Label	1	55	Iron Skateboard Frame	2	79	O-Ring 20.4*2.4	1
06	Cylinder Cover Bumper	1	30	Rubber Grip	1	56	Plastic Skateboard Frame	1	80	Spring	1
07	Hex Bolt M6*25	4	32	Spring Pin 3*28	4	57	Spring	1	81	Spring	1
08	Gun Body Frame	2	33	O-Ring 34.5*2.65	1	58	Safety	1	82	Pin	1
09	Cylinder Cover	1	34	Air Inlet End Cap	1	59	O-Ring 46*2	1	83	Buffer Channel	1
10	Cylinder Cover Sealing Gasket	1	35	Hex Bolt M6*38	2	60	O-Ring 4*1.5	1	84	Spring Holder	1
11	Spring Washer	1	36	Plain Washer	1	61	Nose	1	85	Ring	1
12	Spring Holder	1	38	O-ring 15.8*1.8	1	62	Hex Bolt M6*25	1	86	Nail House Cover	1
13	Spring	1	39	Valve Frame	1	63	Bushing	4	90	Nail Tray Assembly	1
14	Lining Ring	1	40	O-Ring 11.3*1.85	1	64	Cover Plate Pin	4	92	Spring	1
15	O-Ring 51*2.65	2	41	Trigger Valve Bushing	1	65	Fixed Rubber Plug	1	93	Adjust Holder	1
16	O-Ring 42.5*2.5	1	42	O-Ring 19*2.5	1	66	Gun Head Protective Film	1	94	Spring Holder	2
17	On-Off Valve	1	43	O-Ring 6*1.9	1	67	Trigger Piece	1	95	Nail House	1
18	Cylinder Sealing Gasket	1	44	Valve Sleeve	1	68	Spring	1	96	Adjust Holder Seal	1
19	Piston-Driver	1	45	O-Ring 6.4*2	1	69	Spring	1	97	Nail House Pin	1
20	O-Ring 37.5*3.55	1	46	O-Ring 8.9*1.9	1	70	Check Nail Claw	1	98	Hex Bolt V6	2
21	Cylinder	1	47	Trigger Valve Stem Spring	1	71	Cover Plate	1	99	Nose Cap	1
22	O-Ring 48.7*2.65	1	48	Trigger Valve Stem	1	72	Pin 3*12	1	100	Seal Cap	1
23	Sealing Gasket	1	49	O-Ring 2.5*1.5	1	73	Check Nail Pin	1	101	Hex Bolt	1
24	Shaft Washer	1	50	Trigger Sleeve	2	74	Send Nail Claw Spring	1	102	Air Inlet Plug	1
									103	Spring Washer	4

CN55A2 - 062714

# Air Locker

## OPERATING INSTRUCTIONS AND PARTS MANUAL

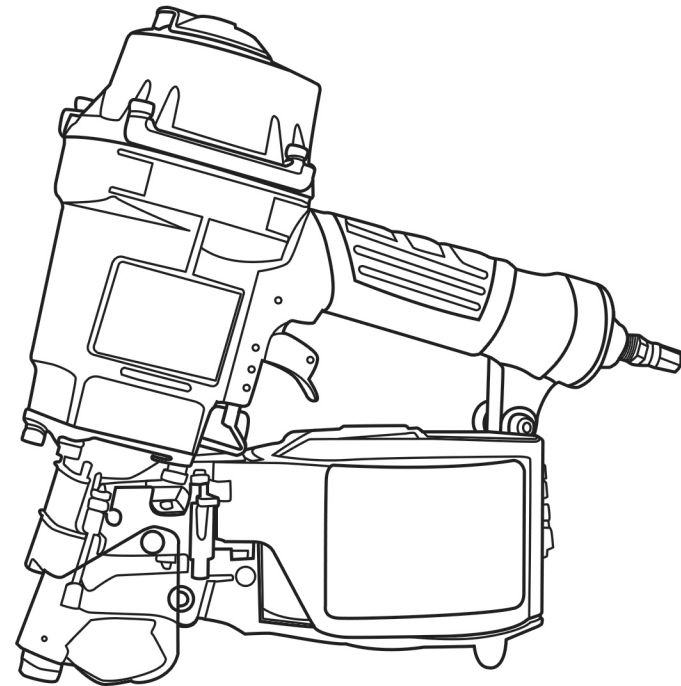

### Industrial Coil Nailer Model: CN55A2



**CAREFULLY READ THIS MANUAL BEFORE OPERATING TOOL!**



## WARNING



**NOTE: Not reading this manual before you use the tool may cause serious injury or even death!**

## PNEUMATIC NAILER OPERATION MANUAL

Please read and fully understand this manual for the information relating to protecting your safety and preventing equipment problem.



**DANGER**



Indicates an immediate hazardous situation, which, if not avoided, will result in serious injury or death.



**WARNING**



Indicates a potentially hazardous situation, which, if not avoided, could result in serious injury or death.



**NOTE**



Alerts the operator to useful information.

- Read and understand the tool label and manual. Read and follow all of the instructions. Failure to follow warnings could result in serious injury or death.
- Operators and others in work area must wear safety glasses with side shields. Safety glasses must conform to the requirements of American National Standards Institute, ANSI Z87.1 and provide protection against flying particles both from the front and side.
- Keep Fingers away from the trigger when not driving fasteners, to avoid accidental firing.
- Never point the tool at any part of your, or another person's body in the work area.
- Never use oxygen, bottled gases, combustible gasses or any other reactive gas as a power source for this tool. Explosion and serious injury could result.
- Wear ear protection to safe-guard against possible hearing damage or hearing loss. Ear protection devices must conform to your local regulations.
- Use clean, dry, regulated compressed air at 70 to 120 PSI. Never connect tool to pressure which potentially exceeds 200 PSI as the tool can burst.
- Only use air hose that is rated for a working pressure of at least 200 PSI or 150% of the maximum system pressure, whichever is greater.
- Disconnect air hose from the tool before performing tool maintenance and inspection, loading fasteners, turning the adjuster and top cover, attaching or removing the nose cap, clearing a jam, it is not in use, leaving work area, moving it to another location and handing it to another person.
- Never use the tool if safety trigger or spring is inoperable, missing or damaged. Do not alter or remove safety, trigger or springs. Make daily inspections for the free movement of the trigger and safety mechanism.
- Disconnect tool from air supply before loading fastener to prevent a fastener from being fired during connection. The tool-driving mechanism may cycle when the tool is connecting to the air supply.
- Operator and bystanders should wear a protective helmet to safe-guard against possible injury.
- Do not load fastener with trigger or safety depressed to prevent unintentional firing of a fastener.
- Do not drive fastener close to the edge of the work piece, the work piece is likely to split which will allow the fastener to fly or ricochet, causing personal injury.
- Never fire fastener into material too hard to penetrate. Do not drive fastener on top of other fasteners, or with the tool at too steep of an angle. The fastener can again ricochet causing personal injury.
- Always carry a fastener-driving tool at the workplace using only the handgrip and never with the trigger actuated. Never carry the tool by the hose or pull the hose to move the tool.

## CONTACT TRIP SAFETY MECHANISM



**DANGER**



- The operator requires finger to be off the trigger and the work contact element (WCE) of the tool to be placed on the work piece.
- The work contact element (WCE) is then depressed against the workplace and the trigger is pulled to drive the fastener.
- The trigger is then released after each fastener is driven. Move the tool to the next location of where the fastener will be driven and repeat the procedure.

## CLEARING A JAM FROM THE TOOL



**WARNING**



- **Fastener jammed in fastener discharge area:** Disconnect the tool from the hose. Open the nozzle part, grab the jammed fastener with pliers and remove. If tool is equipped with a quick release nose cover, open the cover and remove the jammed fastener. Reset the cover.
- **Fastener jam inside magazine:** Disconnect from air supply. Pull back on the magazine cover. Open the nozzle part and remove the jammed fastener. Close the magazine cover.

## CLEANING THE TOOL



**NOTE**



- Always disconnect the tool before cleaning. Remove any tar build-up with WD40 Oil or a cleaning solution. Never soak the tool in any cleaning solution.

## LUBRICATING THE TOOL



**NOTE**



- Disconnect the tool from air supply and add a few drops of air tool oil into the inlet.
- Wipe off excess oil at the exhaust. Excessive oil will damage O-rings of the tool.

## LOADING THE TOOL



**WARNING**



- Make sure that the tool is not connected to an air supply. Do not load the fastener while the air supply is connected to the tool.
- Depress the magazine latch and pull back the magazine cover.
- Insert a stick of fastener into the magazine. Make sure that the pointed ends of the fasteners are loaded with the points downwards. Also make sure the fasteners are not dirty or damaged.
- Push the magazine cover forward until the latch catches.

## OPERATING THE TOOL



**NOTE**



- Lubricate the tool as described above.
- Load the tool with fasteners - as detailed above.
- Attach a high pressure air hose to the inlet of the tool.
- Regulate the air pressure to obtain the air pressure to within the recommended working pressure range outlined in this manual.
- Test for proper fastener penetration by driving few fasteners into a sample piece of wood. If the fasteners do not achieve the desired depth, adjust the air pressure to a higher setting until the desired depth is achieved.